

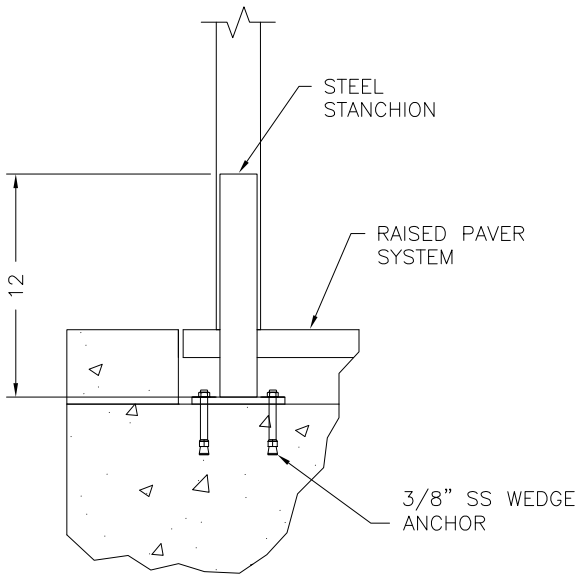

WORLD CLASS ARCHITECTURAL PRODUCTS

HANSEN
ARCHITECTURAL
SYSTEMS

5500 SE ALEXANDER ST. HILLSBORO OR. 97123
PH. 503-356-0959 FAX 503-356-8478



1 STANCHION MOUNTING DETAIL
SCALE: 3

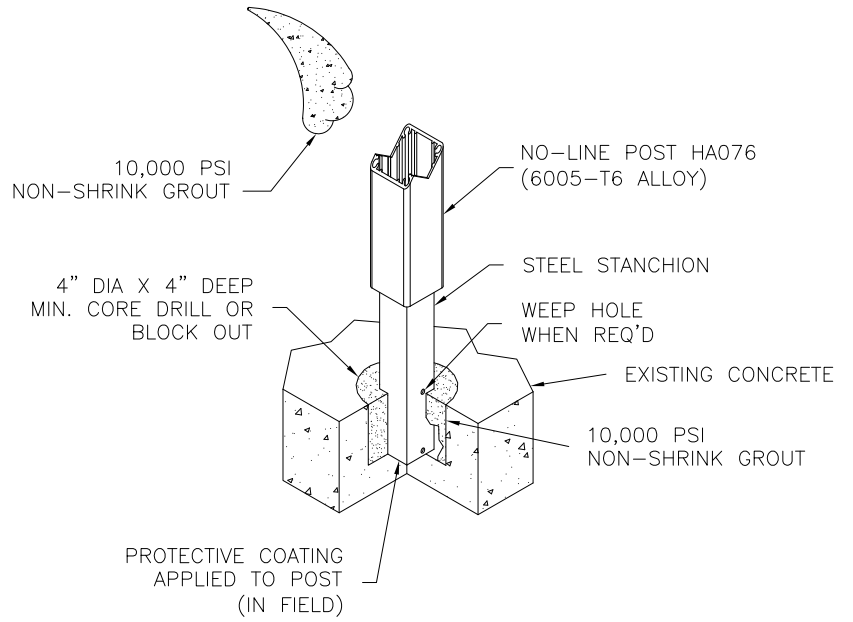

2 STANCHION MOUNTING DETAIL
CORE POCKET OPTION
SCALE: 3

