

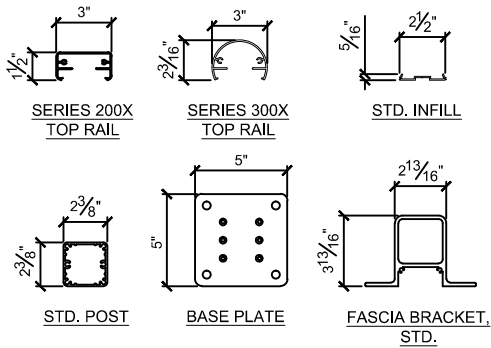

HANSEN ARCHITECTURAL SYSTEMS

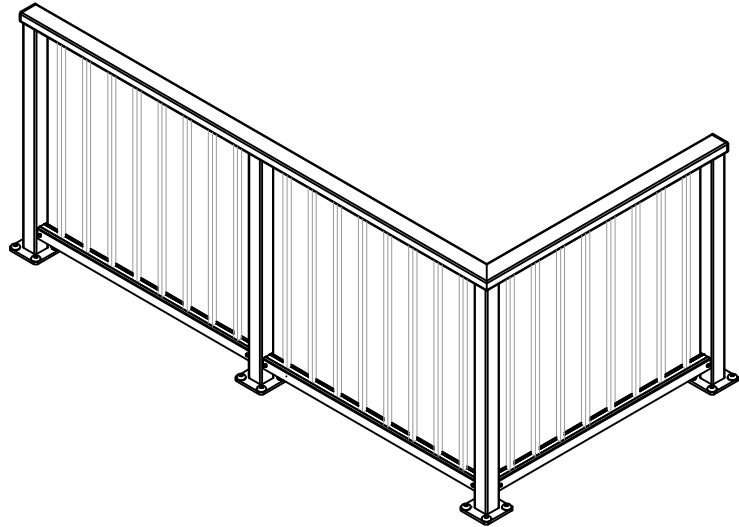

PART PROFILES



TYPICAL ISOMETRIC VIEW

(SERIES 200X, SURFACE MOUNT SHOWN)

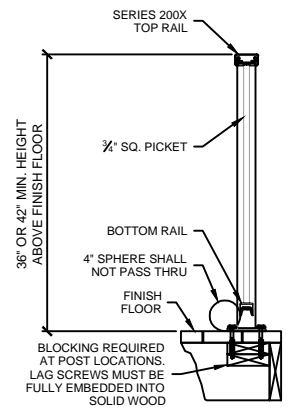

TYPICAL SECTION VIEW

(SERIES 200X, SURFACE MOUNT)

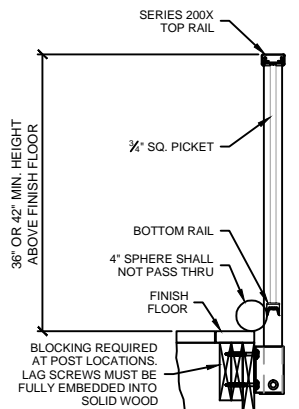

TYPICAL SECTION VIEW

(SERIES 200X, FASCIA MOUNT)

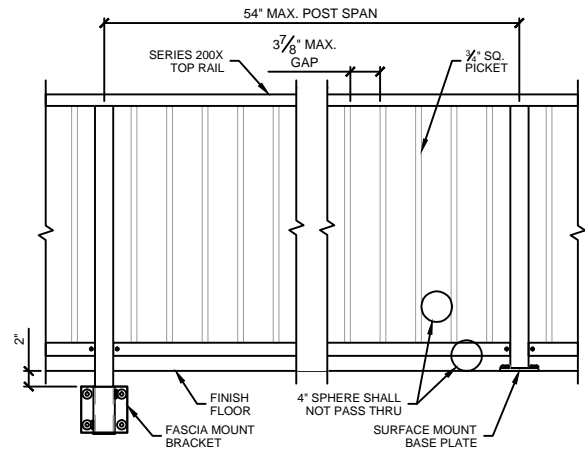

TYPICAL ELEVATION VIEW

(SERIES 200X)

SERIES 200X & 300X PICKET RAILING SYSTEM

5500 SE ALEXANDER ST. HILLSBORO OR. 97123
 PH. 503-356-0959 FAX 503-356-8478
www.aluminumrailing.com



MOUNTING DETAILS

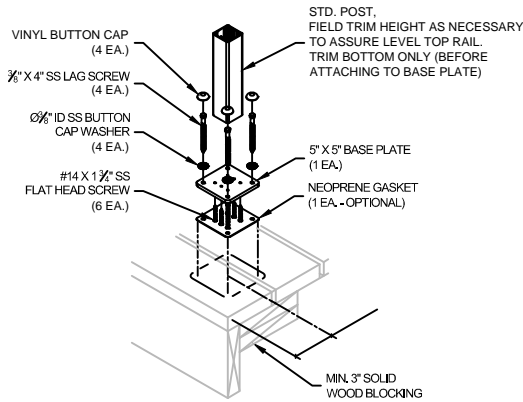

TYP. SURFACE MOUNT TO WOOD CONNECTION

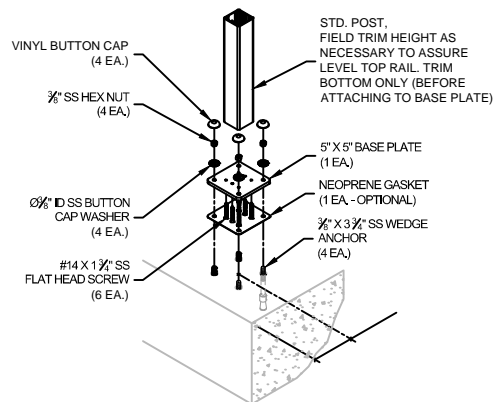

TYP. SURFACE MOUNT TO CONCRETE CONNECTION

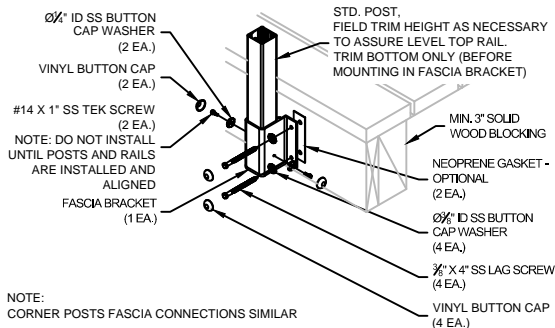

TYP. FASCIA MOUNT TO WOOD CONNECTION

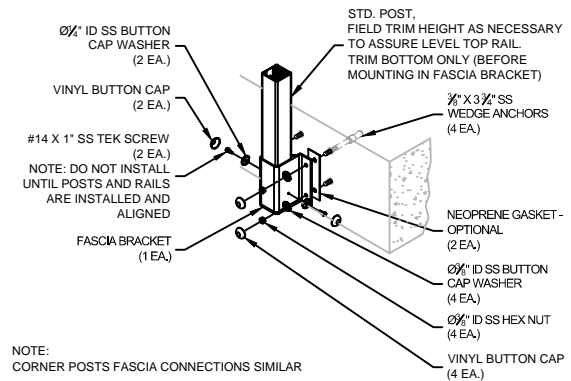

TYP. FASCIA MOUNT TO CONCRETE CONNECTION

SERIES 200X & 300X PICKET RAILING SYSTEM



CONNECTION DETAILS

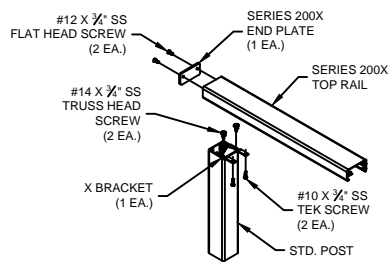

○ TYP. TOP RAIL END CONNECTION

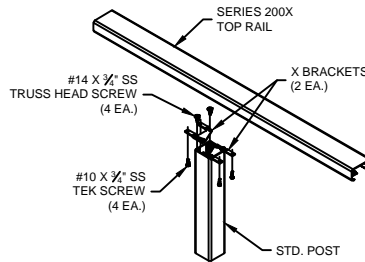

○ TYP. TOP RAIL INLINE CONNECTION

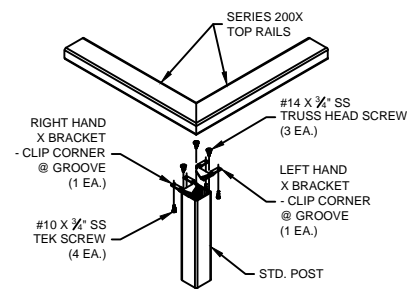

○ TYP. TOP RAIL CORNER CONNECTION

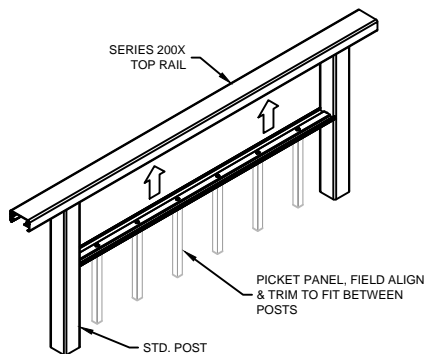

○ TYP. PICKET PANEL TO TOP RAIL CONNECTION

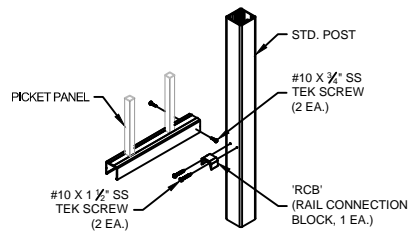

○ TYP. PICKET PANEL TO POST CONNECTION

SERIES 200X & 300X PICKET RAILING SYSTEM

5500 SE ALEXANDER ST. HILLSBORO OR. 97123
PH. 503-356-0959 FAX 503-356-8478
www.aluminumrailing.com